

## A172-UG-BF Series

BARRIER-FREE, WALL MOUNTED UNIVERSAL BI-LEVEL DRINKING FOUNTAIN WITH BOTTLE FILLER

### STANDARD FEATURES

#### Drinking Fountain

- Child or Adult Ada Compliant (When Properly Installed)
- Apron and One-Piece Bottom Wrapper is Satin Finish Or Gray Powder Coat Finish
- Flexible, Low Flow, Antimicrobial, Anti-rotation, Non-squirt Bubbler
- Auto-Stop Allows Cartridge and Strainer Service Without Removing Drinking Fountain To Access Water Supply Stop
- Universal Bi-level Can Be Installed Left High Or Right High With No Additional Parts.
- Lead-Free
- Rough-Ins Match Other Manufacturer's for Easy Replacement

#### Bottle Filler

- Hands-Free Sensor Operation or Pushbutton Operated
- ADA Compliant
- 100-Mesh Inlet Strainer
- 120VAC/9.0VDC Plug-In Transformer, With -BF12 Only
- Laminar Flow Water Supply
- 1 GPM Fill Rate
- -BF12 Sensor Has a 20 Seconds Maximum Run Time

### SUGGESTED SPECIFICATIONS

#### Drinking Fountain

Model A172400F-UG-BF is a self-contained, Bi-Level Drinking Fountain. Unit shall be activated by Chrome Plated Brass Pushbutton using less than 5 pounds of force. Lead-Free Flexible Bubbler shall deliver a 0.3 GPM flow, have an integrally designed Non-Squirt feature and operate on a water pressure range of 20-105 PSIG. Basin shall be constructed from 304 Stainless Steel and have an Integral Drain. Cabinet shall be either Galvanized or Galvannealed Steel with Gray Powder Coat Finish or Stainless Steel with Satin Finish. Unit is certified to ANSI A117.1, Public Law 111-380 (NO-LEAD), CHSC 116875 and NSF/ANSI 61, Section 9. Fixture meets ADA, ADA Standing Person, and ADA Child requirements when mounted appropriately.

#### Bottle Filler -BF11

Bottle Filling unit shall include Pushbutton Operated activation.

#### Bottle Filler -BF12

Bottle Filling unit shall include Sensor Operated activation with a 20 second maximum run time. LED Lights illuminate the Bottle Fill area and brighten when a bottle is detected. Optional -BCD (Bottle Counter Display) indicates the quantity of 16 oz disposable Plastic Bottles saved from a land fill and also displays the Water Filter status. Bottle Filler housing construction will be 20 gauge Stainless Steel with a satin finish and will also include components manufactured from Antimicrobial, impact resistant ABS. Bottle Filler shall provide approximately 1 GPM flow rate with a Laminar Flow Spout to minimize splashing.

Complies with the following standards:



NSF/ANSI 61



Model A172400F-UG-BF11 Shown  
PATENT# 10,100,933  
PATENT# D873,606



**Maintenance Advantage**<sup>®</sup>  
Water Cooler by Murdock Manufacturing

**"RATED FOR INDOOR USE ONLY"**

#### MODEL:

(Must Specify)

#### FLEXIBLE BUBBLER

- A172100F-UG Gray Finish Cooler w/ Satin Finish Bottle Filler (Standard)
- A172400F-UG Satin Stainless Finish (Shown)

#### STAINLESS STEEL BUBBLER

- A172100S-UG Gray Finish Cooler w/ Satin Finish Bottle Filler
- A172400S-UG Satin Stainless Finish

#### MUST SPECIFY BOTTLE FILLER:

- BF11 Bottle Filler with Pushbutton Operation
- BF12 Bottle Filler with Sensor Operation
- BF12-BAT Bottle Filler with Battery Operated Sensor Operation (N/A With -BCD)
- BF12-BCD Bottle Filler with Sensor Operation with Bottle Counter Display

#### DRINKING FOUNTAIN OPTIONS:

(additional costs may apply)

- BP8 Back Panel, Stainless Steel
- CSC6 Concealed Support Carrier
- DD Drop Down Door (with -WF1 Only)
- LOGO Customer Specified Logo / Graphics
- SK5 Skirt Kit for upper unit
- WF1 1500-Gallon Capacity, NSF 42+53, 1-Micron Lead Reduction Filter
- WF3 3000-Gallon Capacity, NSF 42+53, 1-Micron Lead Reduction Filter



Member of  
U.S. Green  
Building  
Council



Recyclable  
Product



Water  
Conserving  
Product

**WARNING:** Cancer and Reproductive Harm - [www.P65Warnings.ca.gov](http://www.P65Warnings.ca.gov)

**A172-UG-BF Series**  
BARRIER-FREE, WALL MOUNTED UNIVERSAL  
BI-LEVEL DRINKING FOUNTAIN WITH  
BOTTLE FILLER

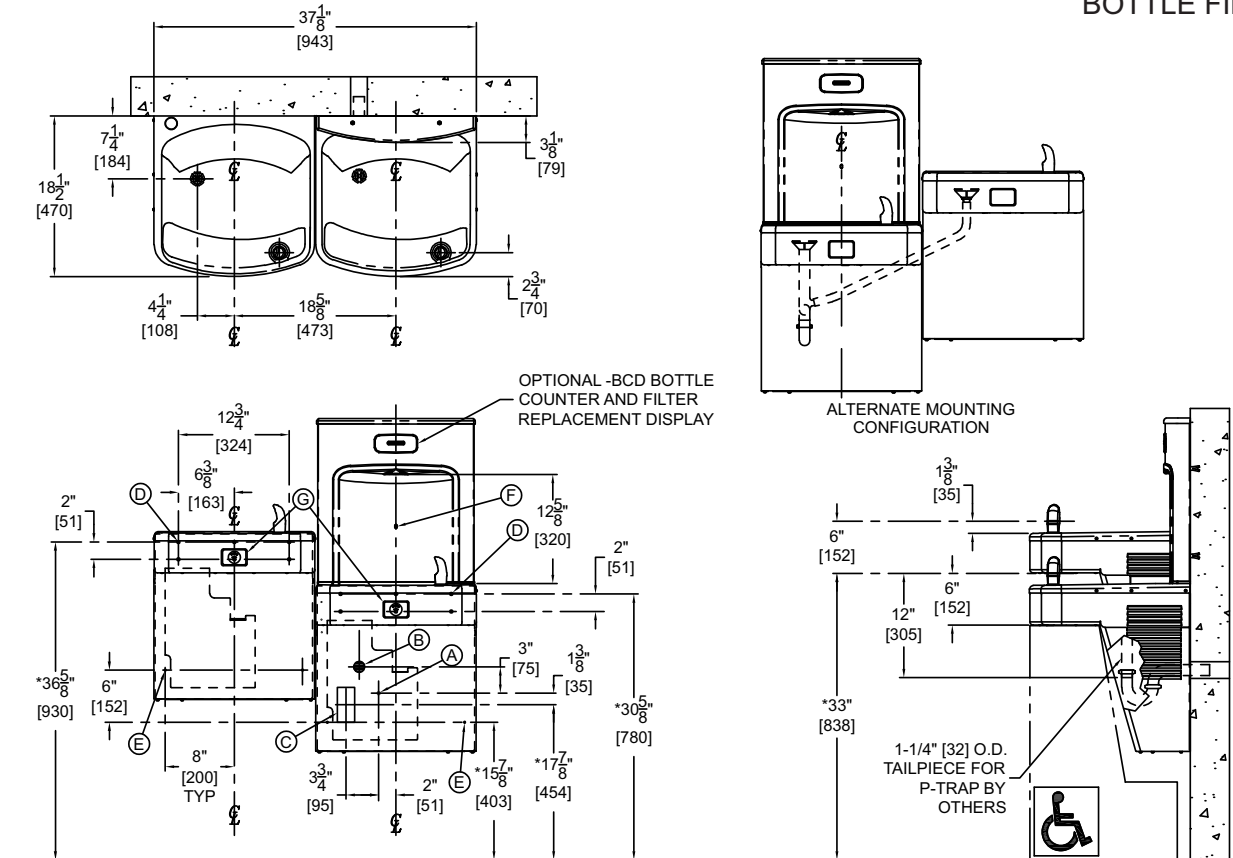

**GENERAL NOTES:**

1. ALL DIMENSIONS ARE IN INCHES [MM]
2. ALLOW 4 INCHES [102MM] MINIMUM CLEARANCE PER SIDE FOR VENTILATION
- \*3. DIMENSIONS SHOWN ARE FOR ADA ADULT HEIGHT. ADJUST VERTICAL DIMENSIONS AS NECESSARY TO COMPLY WITH FEDERAL, STATE & LOCAL CODES
4. STOP VALVE, P-TRAP & ELECTRICAL OUTLET NOT SUPPLIED
5. IMPORTANT: COOLERS MUST BE ATTACHED TO WALL WITH APPROPRIATE ANCHOR SCREWS

- A. 3/8" O.D. SUPPLY INLET
- B. WASTE OUTLET FOR P-TRAP BY OTHERS FOR PROVIDED 1-1/4" O.D. TAILPIECE
- C. ELECTRICAL SERVICE ROUGH-IN FOR OPTIONAL -BF12 SENSOR OPERATED BOTTLE FILLER
- D. Ø3/8" HANGER BRACKET PUNCHING, 6 PLACES FOR ANCHORING HARDWARE BY OTHERS
- E. Ø1/4" PUNCHING, 2 PLACES FOR ANCHORING HARDWARE, BY OTHERS
- F. BOTTLE FILLER SENSOR
- G. PUSHBUTTON CARTRIDGE

Murdock Mfg.™ warrants that its products are free from defects in material or workmanship under normal use and service for a period of 18 months from date of shipment. The sealed refrigeration system is warranted for five years. Murdock's liability under this warranty shall be discharged solely by replacement or repair of defective material, provided Murdock™ is notified in writing within one year from date of shipment, F.O.B. Industry, California.

<b>SELECTION SUMMARY &amp; APPROVAL FOR MANUFACTURING</b>	Model Number & Options _____	Quantity _____	All dimensions are subject to manufactures tolerance of plus or minus 1/2" nominal and subject to change without notice. Murdock assumes no responsibility for use of void or superseded data. Dimensions may change with the addition of optional accessories. Murdock Mfg.™, Member of Morris Group International™. Please visit <a href="http://www.murdockmfg.com">www.murdockmfg.com</a> for most current specifications.
	Company _____		
	Contact _____	Title _____	
	Signature (Approval for Manufacturing) _____	Date _____	